

2100SJ

MEGA TELESCOPIC BOOM LIFT



- 5 steering modes, including lateral drive for exceptional maneuverability
- Industry-leading outreach
- Secondary platform controls for precise positioning
- Patent pending design

 **snorkel**[™]
www.snorkellifts.com

MEGA TELESCOPIC BOOM LIFT

2100SJ

DIMENSIONS	2100SJ*
Max. working height	66.0m
Max. platform height (A)	64.0m
Max. horizontal reach	35.1m
Platform size	2.4m x 0.9m
Overall width (B)	2.5m
Operational width (extended)	5.5m
Stowed length (C)	23.0m
Transport length	15.5m
Stowed height (D)	3.0m
Ground clearance	355mm

PERFORMANCE	
Platform capacity (SWL) (unrestricted)	349kg
Platform capacity (SWL) (restricted)	454kg
Max. drive height	64.0m
Max. wind speed	12.5m/s
Max. drive speed (stowed)	4.0km/h
Max. drive speed (elevated)	0.2km/h
Jib length	9.1m
Jib working arc	128° (-55° to +73°)
Platform rotation	150°
Superstructure rotation (continuous)	360°
Tailswing (axles retracted)	2.05m
Tailswing (axles extended)	0.7m
Raise/lower time	5/5.5 min
Gradeability	35%
Inside turning radius (axles retracted)	3.0m
Inside turning radius (axles extended)	2.6m
Outside turning radius (axles retracted)	5.0m
Outside turning radius (axles extended)	6.4m
Tires	445/50-710 foam filled 24 ply
Controls	proportional joystick
Drive system	4 wheel drive
Working envelope volume	0.2 million m ³

POWER	
Power source	Kubota V3800, 115hp diesel - Tier 4 Final

WEIGHT	
Weight	41,730kg

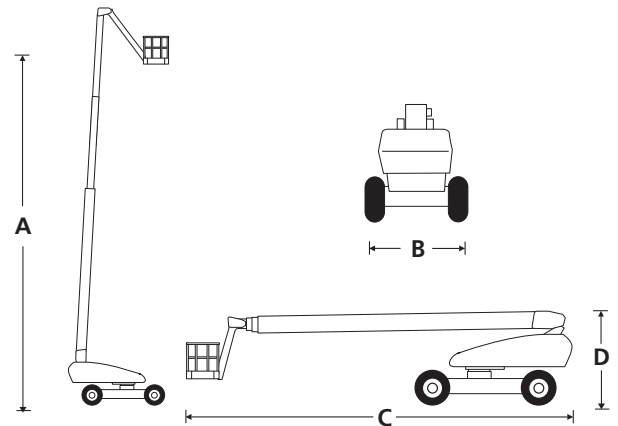

STANDARD FEATURES

- Snorkel Guard™ secondary guarding system
- Secondary platform controls
- 5 steering modes - front axle, rear axle, crab, complementary & lateral
- All proportional controls
- Remote lower control panel
- Tool tray
- Hydraulic platform rotation
- 360° continuous turntable rotation
- Flashing amber light
- Dual lanyard attachment points
- Foam filled tires
- 4-wheel drive
- Power line to platform
- Snorkel OnSite™ telematics - 60 months
- Drive motion alarm
- 2 year parts & labor, 5 year structural warranty

OPTIONS

- Special paint colors
- Airline to platform
- Cold weather package
- Extreme cold weather package
- Extreme environment package
- Light package
- Glazier package
- Environmental hydraulic oil
- AC generator package 110V/240V

WORKING ENVELOPE

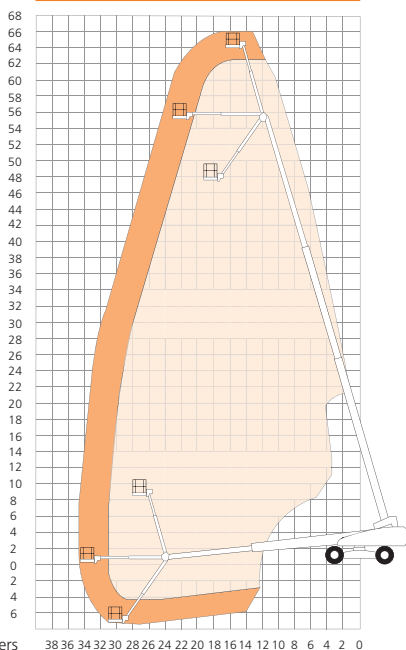

ANSI Specification
© Snorkel 2020

Specifications subject to change without notice. Photos and diagrams in this brochure are for promotional purposes only. Refer to appropriate Snorkel operators manual for detailed instructions on the proper use and maintenance.
*Preliminary specifications – confirm at time of ordering.

snorkel www.snorkellifts.com

P.O. Box 1160
St. Joseph, MO 64502-1160, USA
Tel: 1 (785) 989-3000
Toll-free: 1 (800) 255-0317
Fax: 1 (785) 989-3070
Email: sales.usa@snorkellifts.com

02/2020