

S2770BE/S3370BE/S3970BE

COMPACT BI-ENERGY ROUGH TERRAIN SCISSOR LIFTS



- Compact bi-energy scissor lifts
- Suitable for interior and exterior use
- Non-marking, high grip tires
- Easy to operate
- Ideal for construction sites

 **snorkel**™
www.snorkellifts.com

COMPACT BI-ENERGY SCISSOR RT LIFTS

S2770BE/S3370BE/S3970BE

DIMENSIONS	S2770BE	S3370BE	S3970BE
Max. working height	33 ft	39 ft	45 ft
Max. platform height (A)	27 ft	33 ft	39 ft
Platform size (stowed) (B)	9 ft 8 in x 5 ft 2 in		
Platform size (extended) (C)	13 ft 1 in x 5 ft 2 in		
Extension deck length	4 ft	4 ft	4 ft
Overall width (D)	5 ft 10 in	5 ft 10 in	5 ft 10 in
Overall length (E)	11 ft	11 ft	11 ft
Stowed height (F)	8 ft 7 in	9 ft	9 ft 8 in
Min. height (guardrails folded)	6 ft	6 ft 6 in	7 ft
Ground clearance	13 in	13 in	13 in

PERFORMANCE	S2770BE	S3370BE	S3970BE
Platform capacity (SWL)	1,250 lbs	1,000 lbs	771 lbs
Max. drive height	27 ft	33 ft	39 ft
Max. wind speed	28 mph	28 mph	28 mph
Max. drive speed (stowed) (engine)	2.8 mph	2.8 mph	2.8 mph
Max. drive speed (elevated) (engine)	0.3 mph	0.2 mph	0.2 mph
Raise/lower time (engine)	26/30 sec	50/60 sec	50/60 sec
Gradeability (engine)	35%	35%	30%
Gradeability (batteries)	25%	25%	25%
Max. stabilizer levelling, front to rear	6°	6°	6°
Max. stabilizer levelling, side to side	10°	10°	10°
Inside turning radius	8 ft	8 ft	8 ft
Outside turning radius	15 ft 7 in	15 ft 7 in	15 ft 7 in
Tires	27 x 10.5 - 15 non-marking foam filled		
Controls	proportional joystick		
Drive system	4 wheel drive		

POWER	S2770BE	S3370BE	S3970BE
Power source	Kubota D-902 water cooled diesel 22.5hp - Tier 4 Final and 4 x 6v 305Ah batteries		

WEIGHT	S2770BE	S3370BE	S3970BE
Weight	7,024 lbs	8,642 lbs	9,017 lbs

TURNING RADIUS

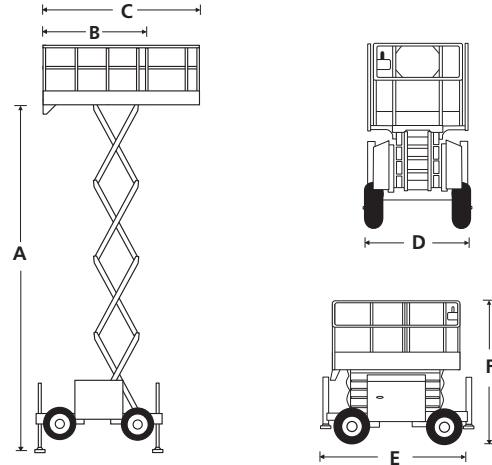
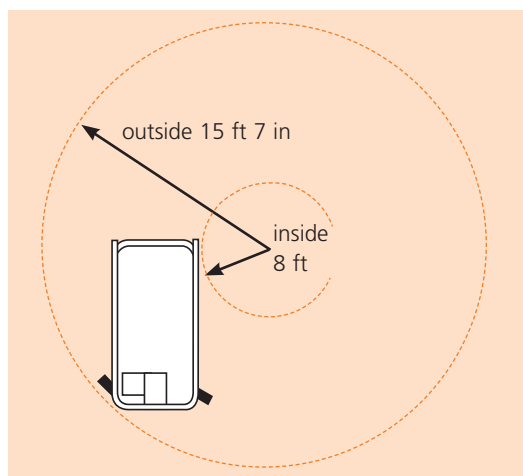

STANDARD FEATURES

- DC and diesel power - for indoor & outdoor work
- 4 wheel drive
- Roll-out deck extension
- 4 hydraulic stabilizers with automatic leveling
- Non-marking foam filled tires
- Proportional controls
- Power line to platform
- Drive motion alarm
- Descent alarm
- Fold-down guardrails
- Flashing amber lights (2)
- Articulating axle
- Hour meter & on-board diagnostics display
- Manual lowering valve
- Dual lanyard attachment points
- 2 year parts & labor, 5 year structural warranty
- ANSI compliant

OPTIONS

- Special paint colors
- Hydraulic generator 110V/2kW
- Nylon spreader pads (set of 4)
- Environmental hydraulic oil
- Cold weather package (block heater + battery warm up)

snorkel

P.O. Box 1160
St. Joseph, MO 64502-1160, USA
Tel: 1 (785) 989-3000
Toll-free: 1 (800) 255-0317
Fax: 1 (785) 989-3070
Email: sales.usa@snorkellifts.com

www.snorkellifts.com