

2100SJ

MEGA TELESCOPIC BOOM LIFT



- 5 steering modes, including lateral drive for exceptional maneuverability
- Industry-leading outreach
- Secondary platform controls for precise positioning
- Patent pending design

 **snorkel**™
www.snorkellifts.com

MEGA TELESCOPIC BOOM LIFT

2100SJ

DIMENSIONS	2100SJ*
Max. working height	216 ft
Max. platform height (A)	210 ft
Max. horizontal reach	115 ft
Platform size	8 ft x 3 ft
Overall width (B) (axles retracted)	8 ft 2 in
Operational width (axles extended)	18 ft
Stowed length (C)	72 ft
Transport length	51 ft
Stowed height (D)	10 ft
Ground clearance	13 in

PERFORMANCE	
Platform capacity (SWL) (unrestricted)	770 lbs
Platform capacity (SWL) (restricted)	1000 lbs
Max. drive height	210 ft
Max. wind speed	28 mph
Max. drive speed (stowed)	2.5 mph
Max. drive speed (elevated)	0.15 mph
Jib length	30 ft
Jib working arc	128° (-55° to +73°)
Platform rotation	150°
Superstructure rotation (continuous)	360°
Tailswing (axles retracted)	80.7 in
Tailswing (axles extended)	27.5 in
Raise/lower time	5/5.5 min
Gradeability	35%
Inside turning radius (axles retracted)	10 ft
Inside turning radius (axles extended)	8 ft 6 in
Outside turning radius (axles retracted)	16 ft 4 in
Outside turning radius (axles extended)	21 ft
Tires	445/50-710 foam filled 24 ply
Controls	proportional joystick
Drive system	4-wheel drive
Working envelope volume	7.11 million ft ³

POWER	
Power source	Kubota V3800, 115 hp - Tier 4 Final

WEIGHT	
Weight	92,000 lbs

WORKING ENVELOPE

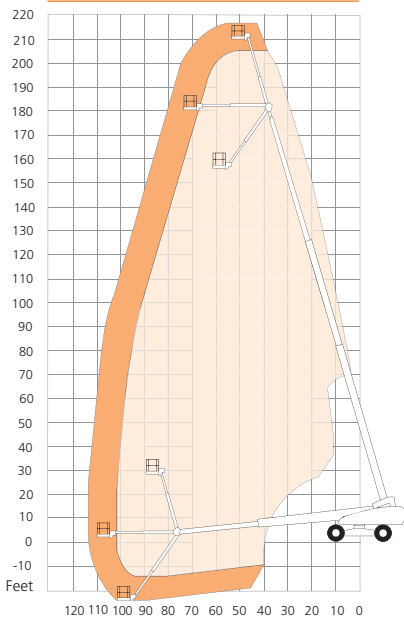

ANSI Specification © Snorkel 2021 Specifications subject to change without notice. Photos and diagrams in this brochure are for promotional purposes only. Refer to appropriate Snorkel operators manual for detailed instructions on the proper use and maintenance. *Preliminary specifications – confirm at time of ordering.

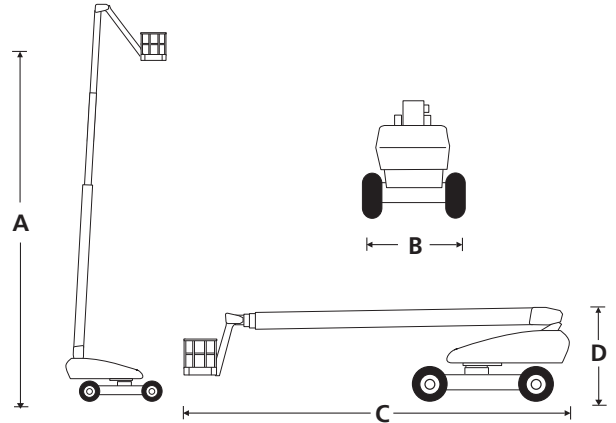

STANDARD FEATURES

- Snorkel Guard™ secondary guarding system
- Secondary platform controls
- Hydraulic platform rotation
- 5 steering modes - front axle, rear axle, crab, complementary & lateral
- 360° continuous turntable rotation
- All proportional controls
- Tool tray
- Remote lower control panel
- Flashing amber light
- Dual lanyard attachment points
- Foam filled tires
- 4-wheel drive
- Power line to platform
- Snorkel OnSite™ telematics - 60 months
- Drive motion alarm
- 2 year parts & labor, 5 year structural warranty
- ANSI compliant

OPTIONS

- Special paint colors
- Airline to platform
- AC generator package 110V/240V
- Cold weather package
- Extreme cold weather package
- Extreme environment package
- Light package
- Glazier package
- Environmental hydraulic oil

snorkel www.snorkellifts.com

P.O. Box 1160
 St. Joseph, MO 64502-1160, USA
 Tel: 1 (785) 989-3000
 Toll-free: 1 (800) 255-0317
 Fax: 1 (785) 989-3070
 Email: sales.usa@snorkellifts.com